



meite®

LOCK

BeA®

VERTEX



FASTENERS INC.



meite®



LOCK



BeA®

VERTEX  FASTENERS INC.





# COIL NAIL

ตะปูม้วน



CN55  
CN70B  
CN80B  
CN100B

## FC : ปalayแหลม

FC32V1	FC38V1	FC45V1	FC45V5	FC50V5	FC57V5	FC65V5	FC75W1	FC90W1	FC100W1
●	●	●	●		●	●		●	
									●

## FS : เกลียวปalayแหลม

FS32V1	FS38V1	FS45V1	FS45V5	FS50V5	FS57V5	FS65V5	FS75W1	FS90W1	FS100W1
●	●	●	●		●	●		●	
									●



CN55  
CN70B  
CN80B  
CN100B

## FC(C) : ปalayตัด

FC32V1C	FC38V1C	FC45V1C	FC45V5C	FC50V5C	FC57V5C	FC65V5C	FC75W1C	FC90W1C	FC100W1C
●	●	●	●		●	●		●	
									●



CN55  
CN70B  
CN80B  
CN100B

## FS(C) : เกลียวปalayตัด

FS32V1C	FS38V1C	FS45V1C	FS45V5C	FS50V5C	FS57V5C	FS65V5C	FS75W1C	FS90W1C	FS100W1C
●	●	●	●		●	●		●	
									●



CN55  
CN70B  
CN80B  
CN100B





meite®

LOCK

BeA®

VERTEX FASTENERS INC.

INDUSTRIAL COIL NAILER

# MEITE INDUSTRIAL COIL NAILER

เครื่องยิงประตู่จิวอน

## CN55

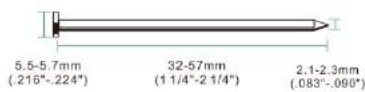

### TOOL SPECIFICATIONS

WEIGHT	2.75 KG / 6.06 LBS
HEIGHT	283MM / 11.14"
LENGTH	270MM / 10.62"
WIDTH	131MM / 5.15"
CAPACITY	300-400 PCS
OPERATING PRESSURE	70-100 PSI
AIR INLET	1/4" NPT
TRIGGER	CONTACT

### FASTENER

TYPE	WIRE / PLASTIC COLLATED COIL NAILS
LENGTH	32-57 MM (1 1/4"-2 1/4")
SHANK DIA	2.1-2.3 MM (.082"-.090")
HEAD DIA	5.5-5.7 MM (.216"-.224")
NAIL PITCH	6.8 MM (.267")
SHANK TYPE	SMOOTH, SCREW & RING

FEATURES	APPLICATIONS	SIMILAR TOOLS
- POWERFUL FOR HEAVY-DUTY APPLICATIONS	- PALLET	- MAX CN55
- WELL-BALANCED, COMFORT RUBBER GRIP	- CRATES & WOOD CASES	- BEA 550DC
- BUMP FIRING TRIGGER FOR HIGH SPEED OPERATION	- SHEATHING	- BOSTITCH N57C
- DURABLE DRIVER AND BUMPER FOR LONG LIFE	- SIDING	- Senco PALLET PRO 57F
- ACCURATE NOSE, MINIMIZE NAIL JAM	- FENCING	
	- DECKING	

## CN70B

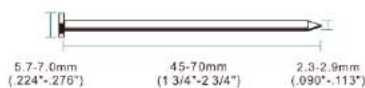

### TOOL SPECIFICATIONS

WEIGHT	3.84 KG / 8.47 LBS
HEIGHT	318 MM / 12.51"
LENGTH	336 MM / 13.22"
WIDTH	143 MM / 5.62"
CAPACITY	225-300 PCS
OPERATING PRESSURE	70-100 PSI
AIR INLET	1/4" NPT
TRIGGER	CONTACT

### FASTENER

TYPE	WIRE / PLASTIC COLLATED COIL NAILS
LENGTH	45-70 MM (1 3/4"- 2 3/4")
SHANK DIA	2.3-2.9MM (0.90"-.114")
HEAD DIA	5.7-7.0 MM (.224".275")
NAIL PITCH	8 MM (.314")
SHANK TYPE	SMOOTH, SCREW & RING

FEATURES	APPLICATIONS	SIMILAR TOOLS
- POWERFUL FOR HEAVY DUTY APPLICATIONS	- PALLETS	- MAX CN70
- WELL-BALANCED, COMFORT RUBBER GRIP	- CRATES & WOOD CASES	- BOSTITCH N57C
- BUMP FIRING TRIGGER FOR HIGH SPEED OPERATION	- FRAMING	- BEA 700DC
- DURABLE DRIVER AND BUMPER FOR LONG LIFE	- DECKING	
- ACCURATE NOSE, MINIMIZE NAIL JAM	- FENCING	
	- PACKAGING	

## CN80B



### TOOL SPECIFICATIONS

WEIGHT	4.02 KG / 8.86 LBS
HEIGHT	348 MM / 13.70"
LENGTH	347 MM / 13.66"
WIDTH	137 MM / 5.39"
CAPACITY	225-300 PCS
OPERATING PRESSURE	70-100 PSI
AIR INLET	1/4" NPT
TRIGGER	CONTACT

### FASTENER

TYPE	WIRE COLLATED COIL NAILS
LENGTH	45-83 MM (1 3/4"-1 3/4")
SHANK DIA	2.5-3.1 MM (0.98"-.122")
HEAD DIA	6.0-7.0 MM (.236"-.275")
NAIL PITCH	8 MM (.314")
SHANK TYPE	SMOOTH, SCREW & RING

FEATURES	APPLICATIONS	SIMILAR TOOLS
- POWERFUL FOR HEAVY DUTY APPLICATIONS	- PALLETS	- MAX CN80
- WELL-BALANCED, COMFORT RUBBER GRIP	- CRATES & WOOD CASES	- BOSTITCH N80CB
- BUMP FIRING TRIGGER FOR HIGH SPEED OPERATION	- PACKAGING	- BEA 800DC
- DURABLE DRIVER AND BUMPER FOR LONG LIFE	- DECKING	
- ACCURATE NOSE, MINIMIZE NAIL JAM	- SHEATHING	

CN100B



TOOL SPECIFICATIONS

WEIGHT	5.67 KG / 12.5 LBS
HEIGHT	420 MM / 16.53"
LENGTH	370 MM / 14.56"
WIDTH	159 MM / 6.25"
CAPACITY	225-300 PCS
OPERATING PRESSURE	100-120 PSI
AIR INLET	3/8" NPT
TRIGGER	CONTACT

FASTENER

TYPE	WIRE / PLASTIC COLLATED COIL NAILS
LENGTH	65-100 MM (2 1/2"-4")
SHANK DIA	2.5-3.3 MM (0.99"-1.31")
HEAD DIA	6.2-7.2 MM (.244"-.283")
NAIL PITCH	10.5 MM (.413")
SHANK TYPE	SMOOTH, SCREW & RING

FEATURES	APPLICATIONS	SIMILAR TOOLS
- POWERFUL FOR HEAVY DUTY APPLICATIONS	- PALLETES	- SENCO PALLET PRO 100
- WELL-BALANCED, COMFORT RUBBER GRIP	- CRATES & WOOD CASES	- BOSTITCH N400C
- RUBBER COMFORT GRIP	- PACKAGING	- MAX GN100
- DOWNWARD DIRECTIONAL EXHAUST	- DECKING	
- DURABLE DRIVER AND BUMPER FOR LONG LIFE	- SHEATHING	

MEITE HEAVY WIRE STAPLER SERIES

เครื่องยิงลวดตอก

N851F



TOOL SPECIFICATIONS

WEIGHT	2.8 KG / 6.17 LBS
HEIGHT	287 MM / 11.29"
LENGTH	340 MM / 13.38"
WIDTH	100 MM / 3.93"
CAPACITY	140 PCS
OPERATING PRESSURE	80-120 PSI
AIR INLET	1/4" NPT
TRIGGER	CONTACT

FASTENER

TYPE	16 GA HEAVY WIRE STAPLES
LENGTH	25-50 MM (1"-2")
SHANK DIA	1.6 MM (.062")
HEAD DIA	1.4 MM (.055")
NAIL PITCH	10.8 MM (7/16")
SHANK TYPE	GLUED STRIP

FEATURES	APPLICATIONS	SIMILAR TOOLS
- POWERFUL	- SOLID WOOD FURNITURE	- BEA 14/50-763
- RUBBER COMFORT GRIP	- WOODEN PACKING BOXES	- SENCO SN45XP
- WELL-BALANCED	- SOFA FRAME	- HITACHI N5008A
	- SHEATHING	- BOSTITCH 650S5-1
	- ROOF DECKING	
	- SUBFLOORING ETC	

PW2538

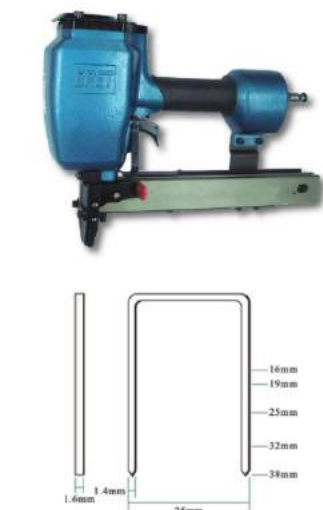

TOOL SPECIFICATIONS

WEIGHT	3.37 KG / 7.43 LBS
L X W X H	350 X 100 X 287 (MM)
	14" X 4" X 11 1/2"
CAPACITY	140 PCS
AIR PRESSURE	80-120 PSI
AIR INLET	3/8" NPT

FASTENER

LENGTH	16-38 MM (5/8"-1 1/2")
WIDTH X THICKNESS:	1.6 X 1.4 MM (.063" X .055")
CROWN	26.4 MM (1")
COLLATION TYPE	GLUED STRIP

FEATURES	APPLICATIONS	SIMILAR TOOLS
- POWERFUL FOR HEAVY DUTY APPLICATIONS	- WINDOW DOOR	- SENCO WC150XP
- RUBBER COMFORT GRIP	- CORRUGATED CARTON TO SKID	- BOSTITCH 43852-1
- LIGHT WEIGHT		



# MEITE NAIL REMOVING เครื่องถอนตะปู

T50SC



### TOOL SPECIFICATIONS

WEIGHT	1.06KG / 2.34LBS	CAPACITY	/
HEIGHT	228MM / 8.97"	OPERATING PRESSURE	60-100PSI
LENGTH	282MM / 11.10"	AIR INLET	1/4"NPT
WIDTH	62MM / 2.44"	TRIGGER	TRIGGER

FEATURES	APPLICATIONS
TOOL FOR PALLET REPAIRING	PALLET
LIGHT WEIGHT & WELL - BALANCED	CRATES & WOOD CASES
RUBBER COMFORT GRIP	PACKAGING
DURABLE DRIVER AND BUMPER FOR LONG LIFE	

NP55



### TOOL SPECIFICATIONS

WEIGHT	2.0KG / 4.41LBS	CAPACITY	/
HEIGHT	276MM / 10.86"	OPERATING PRESSURE	60-100PSI
LENGTH	298MM / 11.73"	AIR INLET	1/4"NPT
WIDTH	88MM / 3.46"	TRIGGER	TRIGGER

FEATURES	APPLICATIONS
TOOL FOR PALLET REPAIRING	PALLET
LIGHT WEIGHT & WELL - BALANCED	CRATES & WOOD CASES
RUBBER COMFORT GRIP	PACKAGING
DURABLE DRIVER AND BUMPER FOR LONG LIFE	
POWERFUL FOR HEAVY-DUTY APPLICATIONS	

NP70



### TOOL SPECIFICATIONS

WEIGHT	2.73KG / 6.02LBS	CAPACITY	/
HEIGHT	109MM / 4.29"	OPERATING PRESSURE	85-115PSI
LENGTH	343MM / 13.50"	AIR INLET	1/4"NPT
WIDTH	303MM / 11.92"	TRIGGER	TRIGGER

FEATURES	APPLICATIONS
TOOL FOR PALLET REPAIRING	PALLET
LIGHT WEIGHT & WELL - BALANCED	CRATES & WOOD CASES
RUBBER COMFORT GRIP	PACKAGING
DURABLE DRIVER AND BUMPER FOR LONG LIFE	
POWERFUL FOR HEAVY-DUTY APPLICATIONS	



## TSN STAPLER

เครื่องยิงลวดและเครื่องยิงตะปูแฉง

STAPLER เครื่องยิงตะปูแฉง  
รุ่น TSN-30 / F30 สำหรับงานไม้

## SPECIFICATIONS

น้ำหนัก	1.2 กก.
ขนาด (ก x ย x อ)	50 X 240 X 175
ความจุตะปู	100 ตัว
ความดันลม	4 - 7 กก. / ตร.ซม.
ขนาดเส้นผ่าศูนย์กลางภายในของสายลม	5 มม.

## TSN FINISHNAIL (STEEL, STAINLESS)

ตะปูแฉงหัวกลม "ฟิวเอชเอ็น" ทำจากเหล็กชุบสังกะสี และสแตนเลส ลวดทอ 3 สัปดาห์ ยิงได้ 3000 และ 5000 ตัว

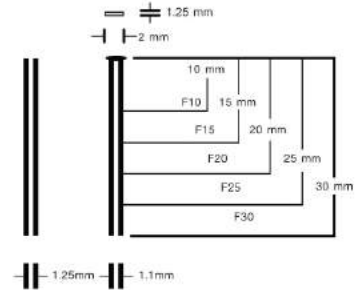
STAPLER เครื่องยิงลวด  
รุ่น TSN-20 / 1013J

## SPECIFICATIONS

ความจุลวด	100 ตัว
น้ำหนักเครื่อง	0.91 กก.
ความดันลม	3.5 - 7 กก. / ตร.ซม.
ขนาดรูในของสายลม	5 มม.

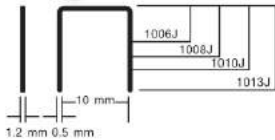
STAPLER เครื่องยิงลวด  
รุ่น TSN-30 / 1022J

## SPECIFICATIONS

ความจุลวด	100 ตัว
น้ำหนักเครื่อง	1.2 กก.
ความดันลม	4 - 7 กก. / ตร.ซม.
ขนาดรูในของสายลม	5 มม.

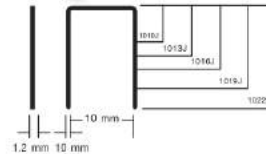

## BEA STAPLER

เครื่องยิงลวด

FINE WIRE STAPLER  
รุ่น J10/16-435

## SPECIFICATIONS

WEIGHT	0.9 KG
L X W X H	228 X 42 X 152
OPERATING PRESSURE	5-8 BAR
ใช้ลวด	1004 - 1016J

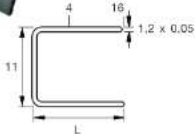
MEDIUM DUTY STAPLER  
รุ่น 90/40-711

## SPECIFICATIONS

WEIGHT	2.1 KG
L X W X H	343 X 70 X 228
OPERATING PRESSURE	5-8 BAR
ใช้ลวด	92/15 - 92/40

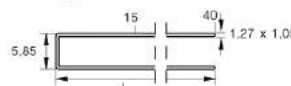
HEAVY DUTY STAPLER  
รุ่น 14/50-763

## SPECIFICATIONS

WEIGHT	2.14 KG
L X W X H	334 X 70 X 244
OPERATING PRESSURE	5-8 BAR
ใช้ลวด	825T - 850T

MEDIUM DUTY STAPLER  
รุ่น 92/40-722

## SPECIFICATIONS

WEIGHT	1.34 KG
L X W X H	221 X 70 X 228
OPERATING PRESSURE	5-8 BAR
ใช้ลวด	415MA - 440MA





meite®

LOCK

BeA®

VERTEX FASTENERS INC.

C-RING PLIER SERIES

# MEITE C-RING PLIER SERIES

## MEITE C-Ring

### SC760B



#### TOOL SPECIFICATIONS

WEIGHT	1.63KG/3.59LBS
HEIGHT	201MM/7.91"
LENGTH	330MM/12.99"
WIDTH	84MM/3.30"
CAPACITY	100PCS
OPERATING PRESSURE	70-100PSI
AIR INLET	1/4"NPT
TRIGGER	TRIGGER

#### FASTENER

TYPE	TAPE COLLATED C-RING
LENGTH	1.6GA
SHANK DIA	1.6MM(.063")
HEAD DIA	12.5MM(1/2")
NAIL PITCH	2.6-3.6MM(.102"-1.41")
SHANK TYPE	GALVANIZED, ALUMINUM, STAINLESS

#### FEATURES

- WELL-BALANCED, ERGONOMICALLY DESIGNED
- LARGE CAPACITY LONG MAGAZINE
- RUBBER COMFORT GRIP
- CAN BE EASILY CONVERTED TO RIGHT OR LEFT HAND OPERATION

#### APPLICATIONS

- WIRE CAGE
- CAR SEAT
- SPRING MATTRESS
- BAG CLOSURE

#### SIMILAR TOOLS

- BOSTITCH SC760
- MEIHO MC-660

### SC7C



#### TOOL SPECIFICATIONS

WEIGHT	1.68KG/3.70LBS
HEIGHT	201MM/7.91"
LENGTH	338MM/13.30"
WIDTH	84MM/3.30"
CAPACITY	100PCS
OPERATING PRESSURE	70-100PSI
AIR INLET	1/4"NPT
TRIGGER	TRIGGER

#### FASTENER

TYPE	TAPE COLLATED C-RING
LENGTH	1.5GA
SHANK DIA	1.8MM(.070")
HEAD DIA	19MM(3/4")
NAIL PITCH	5.7-7.0MM(.224"-.275")
SHANK TYPE	GALVANIZED, ALUMINUM, STAINLESS

#### FEATURES

- WELL-BALANCED, ERGONOMICALLY DESIGNED
- LARGE CAPACITY LONG MAGAZINE
- RUBBER COMFORT GRIP
- CAN BE EASILY CONVERTED TO RIGHT OR LEFT HAND OPERATION

#### APPLICATIONS

- WIRE CAGE
- CAR SEAT
- SPRING MATTRESS
- BAG CLOSURE

#### SIMILAR TOOLS

- BOSTITCH SC7C
- MEIHO MC-6CA

### SC7E

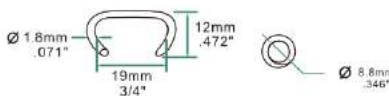

#### TOOL SPECIFICATIONS

WEIGHT	1.74KG/3.84LBS
HEIGHT	201MM/7.91"
LENGTH	349MM/13.74"
WIDTH	84MM/3.30"
CAPACITY	100PCS
OPERATING PRESSURE	70-100PSI
AIR INLET	1/4"NPT
TRIGGER	TRIGGER

#### FASTENER

TYPE	TAPE COLLATED C-RING
LENGTH	1.5GA
SHANK DIA	1.8MM(.070")
HEAD DIA	19MM(3/4")
NAIL PITCH	6.8MM(.346")
SHANK TYPE	GALVANIZED, ALUMINUM, STAINLESS

#### FEATURES

- WELL-BALANCED, ERGONOMICALLY DESIGNED
- LARGE CAPACITY LONG MAGAZINE
- RUBBER COMFORT GRIP
- CAN BE EASILY CONVERTED TO RIGHT OR LEFT HAND OPERATION

#### APPLICATIONS

- WIRE CAGE
- CAR SEAT
- SPRING MATTRESS
- BAG CLOSURE

#### SIMILAR TOOLS

- BEA CL24
- BOSTITCH SC7E
- MEIHO MC-6LNA

### SC77XE



#### TOOL SPECIFICATIONS

WEIGHT	1.815KG/4.0LBS
HEIGHT	216MM/8.50"
LENGTH	375MM/14.76"
WIDTH	88MM/3.46"
CAPACITY	100PCS
OPERATING PRESSURE	70-100PSI
AIR INLET	1/4"NPT
TRIGGER	TRIGGER

#### FASTENER

TYPE	TAPE COLLATED C-RING
LENGTH	1.5GA
SHANK DIA	1.8MM(.070")
HEAD DIA	19MM(3/4")
NAIL PITCH	8.8MM(.346")
SHANK TYPE	GALVANIZED, ALUMINUM, STAINLESS

#### FEATURES

- WELL-BALANCED, ERGONOMICALLY DESIGNED
- LARGE CAPACITY LONG MAGAZINE
- RUBBER COMFORT GRIP
- CAN BE EASILY CONVERTED TO RIGHT OR LEFT HAND OPERATION

#### APPLICATIONS

- WIRE CAGE
- CAR SEAT
- SPRING MATTRESS
- BAG CLOSURE

#### SIMILAR TOOLS

- BOSTITCH SC77XE



## VERTEX CLIPPING TOOL & SPRING STAPLER

เครื่องยิงคลิป

### ProClinch™ Clipping Tool



PC4-6080 สำหรับ Clip No.73, 74

PC4-6181 สำหรับ Clip No.3, 4

PC4-6183 สำหรับ Clip No.34

PC4-6189 สำหรับ Clip No.36

#### Patented polycord collation benefits

- Unlimited shelf life compared to tape-collated clips.
- Ship and handle without breaking.
- Easy to load.
- No residue as with tape-collated clips that can gum up tools, causing increased tool maintenance.
- Welded clips can cause user injuries and can increase tool maintenance.
- Patented "cord lock" collation eliminates jams associated with cords not shearing from clips.

#### Features

- Lightweight – 35% lighter than competitive models, meaning higher productivity with less operator fatigue.
- 40% fewer components – fewer problems, less maintenance, and increased productivity.
- Easier to handle – the ergonomic design reduces the overall handle-to-trigger dimension by 13%, which makes the tool feel more comfortable to operators with large or small hands.
- Innovative design – includes the use of composite materials and investment castings to ensure light weight, high quality, low maintenance, and increased durability.
- Vertex Fasteners offers many optional accessories for the ProClinch line, including:
  - Blade jam release devices.
  - Pivoting anvils.
  - Fixtured tools.
  - Tool hangers.
  - Counter balancers.
  - Remote activation.
  - Custom features – Vertex engineers will work with you to analyze your application and design a custom solution.

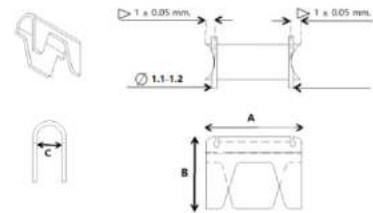

Dimensions				
Product	Vertex NO.	A Width	B Height	C Inside
CL-3	804235	21.8mm	12.7mm	6.2mm
CL-4	804235	21.8mm	14mm	6.2mm
CL-34	101H235	21.8mm	17.2mm	6.2mm
CL-71		18.5mm	13.5mm	6.2mm
CL-72	91723	18.5mm	14.5mm	6.2mm
CLP-312	80723	18.5mm	12.7mm	5.6mm

### ProStick™ Spring Stapler

เครื่องยิงลวดทาส์กิ้ง



#### VA0317

Single Staple, Standard Weight

WEIGHT	*7.04 IBS. (STANDARD WEIGHT) 5.56 IBS. (LIGHTWEIGHT)"
HEIGHT	35"
WIDTH	2.5"
LENGTH	14"

#### VA0318

Double Staple, Standard Weight

WEIGHT	*7.04 IBS. (STANDARD WEIGHT) 5.56 IBS. (LIGHTWEIGHT)"
HEIGHT	35"
WIDTH	2.5"
LENGTH	14"

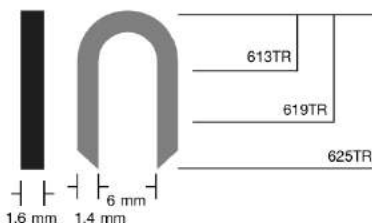

#### Features

- The QuietFire™ valve greatly reduces tool exhaust noise.
- All ProStick™ parts are completely interchangeable with competitors' model BCAR tools.
- Tools and parts are a fraction of the cost of our competitors'.
- Conversion kits are available to convert your current tools to "Lightweight" or "QuietFire™" tools.
- Rounded lower handgrip, with no-slip lip, gives better control and increased operator comfort.
- Built-in flats on the handle make tool disassembly a breeze.
- Vertex WireLok™ spring staples incorporate 2 separate adhesives, resulting in superior holding power.





meite® LOCK

BeA®

VERTEX FASTENERS INC.

STAPLER

## LOCK CARTON STAPLER

เครื่องเย็บฟากกล่อง

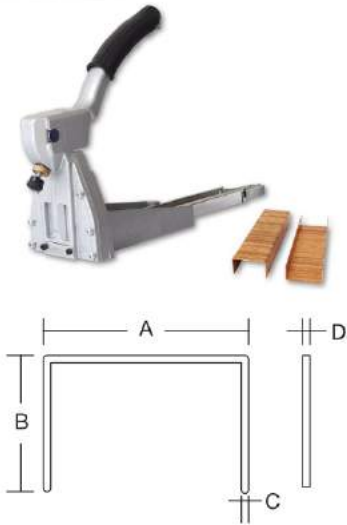

**888-BIII** เครื่องเย็บฟากกล่องใช้มือกด  
 LOCK standard stapler.  
 Handy & easy  
 Air / Electric power-free

### SPECIFICATIONS

น้ำหนัก	2.1 กก.
ขนาด (กxยxส)	110x430x280
ความดันลม	-
ปริมาณลม	-

	3416	3419
A	34 mm	34 mm
B	16 mm	19 mm
C	0.78 mm	0.78 mm
D	2.27 mm	2.27 mm

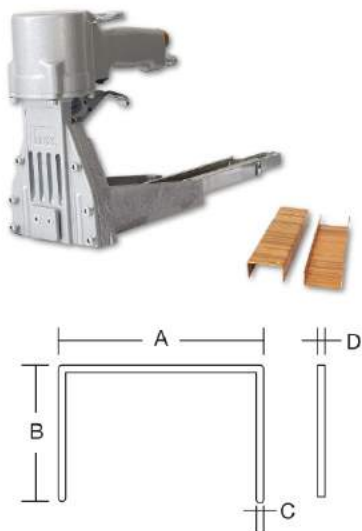

**888-CNT** เครื่องเย็บฟากกล่องใช้ลม  
 Compact model of 888-CN  
 Lightweight, work easily  
 Silencer installed.  
 Also suitable for indoors work, of course.

### SPECIFICATIONS

น้ำหนัก	2.4 กก.
ขนาด (กxยxส)	110X410X210
ความดันลม	6-7 กก. / ตร.ซม.
ปริมาณลม	2.0 ลิตร / 1 ชิ้น

	3416	3419
A	34 mm	34 mm
B	16 mm	19 mm
C	0.78 mm	0.78 mm
D	2.27 mm	2.27 mm

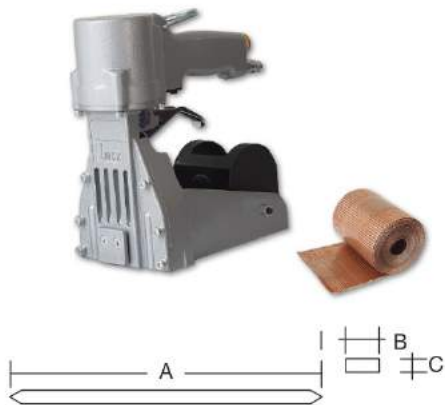

**888-CRN** เครื่องเย็บฟากกล่องลวดม้วนใช้ลม  
 Compact model of 888-CR  
 Light weight, work easily  
 An astonishing rapid performance  
 Silencer installed

### SPECIFICATIONS

น้ำหนัก	2.8 กก.
ขนาด (กxยxส)	110X215X210
ความดันลม	6-7 กก./ตร.ซม.
ปริมาณลม	2.0 ลิตร / 1 ชิ้น

1M = 1,000 pcs / Roll

5M = 5,000 pcs / Roll

	CCS18C-1M,5M	CCS18G-1M,5M
A	64 mm	65 mm
B	1.9 mm	1.9 mm
C	0.85 mm	0.85 mm

# TSN CARTON STAPLER

เครื่องเย็บฟากกล่อง

## CARTON STAPLER

เครื่องเย็บฟากกล่อง



TSN-HA-19-35



TSN-AA-19-35



TSN-AA-22-35

## CARTON BOTTOMER

เครื่องเย็บก้นกล่อง



TSN-CMB-S-35



TSN-CAB-S-35

### SPECIFICATIONS

MODEL	W X L X H (CM.)	WEIGHT (CM.)	STAPLE LENGTH (CM.)	STAPLE CAPACITY (PCS.)	OPERATION TYPE
TSN-HA-19-35	11.5 X 43.3 X 22	2.2	15,16,18,19	100	MANUAL
TSN-AA-19-35	11.5 X 41.5 X 22	2.65	15,16,18,19	100	AIR (5-7 KG. / CM <sup>2</sup> )
TSN-AA-22-35	11.5 X 41.5 X 22	2.65	22	100	AIR (5-7 KG. / CM <sup>2</sup> )
TSN-CMB-S-35	60 X 91 X 124.5	26.8	15,16,18,19,22	200	MANUAL
TSN-CAB-S-35	60 X 83 X 124.5	22.7	15,16,18,19,22	200	AIR (5.5-6 KG. / CM <sup>2</sup> )



### SPECIFICATIONS OF STEEL STAPLE

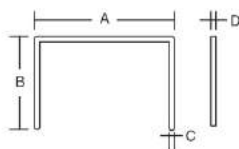

	3415	3416	3419	3422
A	34 mm	34 mm	34 mm	34 mm
B	15 mm	16 mm	19 mm	22 mm
C	0.78 mm	0.78 mm	0.78 mm	0.78 mm
D	2.27 mm	2.27 mm	2.27 mm	2.27 mm

### SPECIFICATIONS OF ROLL STAPLE



	CCS18C-1M,5M 1M = 1,000 pcs / Roll	CCS18G-1M,5M 5M = 5,000 pcs / Roll
A	64 mm	64 mm
B	1.9 mm	1.9 mm
C	0.85 mm	0.85 mm