

SGSPRO BUR SHAPES



SGSPRO tungsten carbide burs are manufactured in compliance with the highest standards. Our comprehensive product portfolio offers a broad range of reliable and market-proven solutions for every application. Our know-how and expertise allow us to continuously improve our offering to provide outstanding quality and deliver excellent performance across a wide range of industries, optimizing processes in regards to economic efficiency, safety and process optimization.

Customer Support

Our customer service team is available to answer any questions you may have. Our technical support team is available to discuss any requirements you may have and provide you with a tailor-made solution.

Application Tips

- Use lubricant or wax to prevent flute loading in soft materials.
- Using the recommended speed prevents premature wear and/or insufficient material removal rates.
- Maintain grinder concentricity to optimize material removal rates and extend bur life.
- Reduce flutes and increase speed in softer materials. Increase flutes and reduce speed in hardened materials.
- Cross cut styles (6, 3SP, 4) generally improve stock removal, control, and reduce chip size.

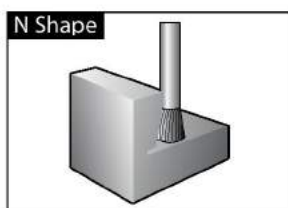
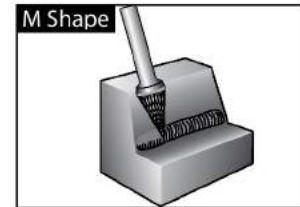
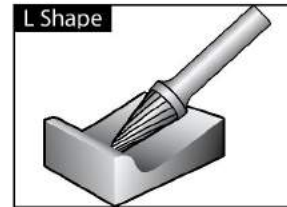
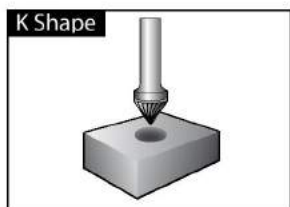
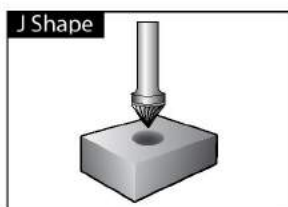
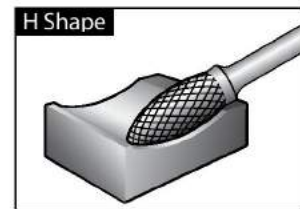
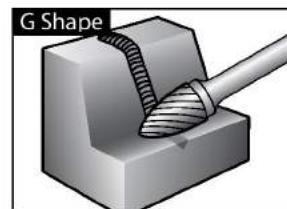
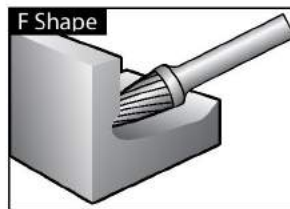
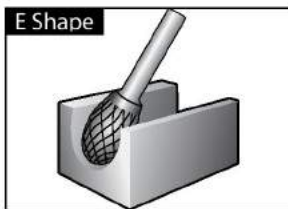
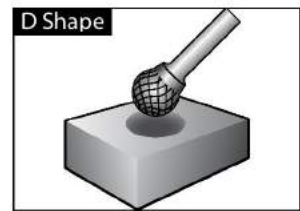
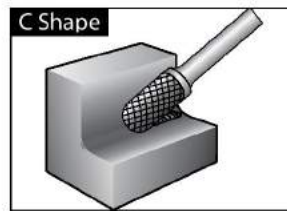
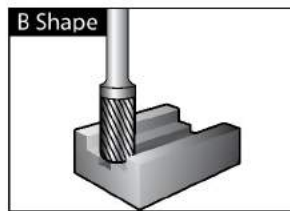
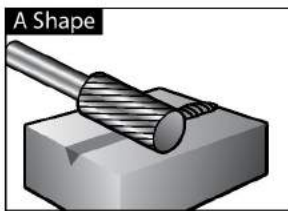

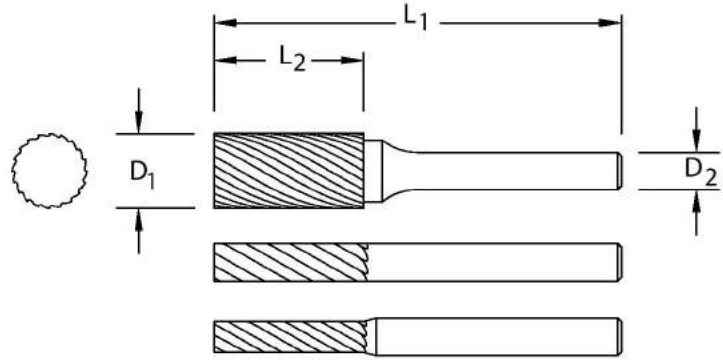

Universal SA - Cylinder Shape

Tool No.	Cutting Diameter D1	Length of Cut L2	Shank Diameter D2	Overall Length L1	Double Cut 6 EDP No.	Single Cut 3 EDP No.	Nonferrous Cut 1 EDP No.
SA-41	1/16	1/4	1/8	1-1/2	10603	10600	-
SA-41L2	1/16	1/4	1/8	2	17103	17100	-
SA-41L3	1/16	1/4	1/8	3	17128	17125	-
SA-61	1/16	1/4	3/32	1-1/4	10753	10750	-
SA-63	3/32	3/8	3/32	1-1/4	10778	10775	-
SA-42	3/32	7/16	1/8	1-1/2	10628	10625	-
SA-42L2	3/32	7/16	1/8	2	17153	17150	-
SA-42L3	3/32	7/16	1/8	3	17178	17175	-
SA-11	1/8	1/2	1/4	2-1/4	10403	10400	-
SA-43	1/8	9/16	1/8	1-1/2	10653	10650	-
SA-43L2	1/8	9/16	1/8	2	17203	17200	-
SA-43L3	1/8	9/16	1/8	3	17228	17225	-
SA-12	1/8	5/8	1/4	2-3/8	10428	10425	-
SA-52	5/32	1/2	1/8	1-1/2	10703	10700	-
SA-13	5/32	5/8	1/4	2	10453	10450	-
SA-81	3/16	1/2	3/16	2	10803	10800	-
SA-53	3/16	1/2	1/8	1-1/2	10728	10725	-
SA-14	3/16	5/8	1/4	2	10478	10475	-
SA-51	1/4	1/2	1/8	2	10678	10675	-
SA-1	1/4	5/8	1/4	2	10003	10000	-
SA-1L	1/4	1	1/4	2	10028	10025	-
SA-1L6	1/4	5/8	1/4	6-1/2	16178	16175	-



Recommended Air Tools

FEATURES
From finishing to stock removal

TOOL
Die Grinders & Pencil Grinders



Wear Eye Protection!



Wear Hearing Protection!



Observe the recommended rotational speed, especially when using burs with long shanks!



Wear Protective Gloves



Universal SA - Cylinder Shape

Tool No.	Cutting Diameter D1	Length of Cut L2	Shank Diameter D2	Overall Length L1	Double Cut 6 EDP No.	Single Cut 3 EDP No.	Nonferrous Cut 1 EDP No.
SA-1NF	1/4	3/4	1/4	2	–	–	19000
SA-2	5/16	3/4	1/4	2-1/2	10053	10050	–
SA-3	3/8	3/4	1/4	2-1/2	10078	10075	–
SA-3L	3/8	1	1/4	2-3/4	10103	10100	–
SA-3L6	3/8	3/4	1/4	6-3/4	16203	16200	–
SA-3NF	3/8	3/4	1/4	2-1/2	–	–	19002
SA-3X	3/8	1-1/2	1/4	3-1/4	10128	10125	–
SA-4	7/16	1	1/4	2-3/4	10153	10150	–
SA-5	1/2	1	1/4	2-3/4	10178	10175	–
SA-5L6	1/2	1	1/4	7	16228	16225	–
SA-5NF	1/2	1	1/4	2-3/4	–	–	19004
*SA-6	5/8	1	1/4	2-3/4	10203	10200	–
*SA-6NF	5/8	1	1/4	2-3/4	–	–	19006
*SA-15	3/4	1/2	1/4	2-1/4	10503	10500	–
*SA-16	3/4	3/4	1/4	2-1/2	10553	10550	–
*SA-7	3/4	1	1/4	2-3/4	10253	10250	–
SA-7NF	3/4	1	1/4	2-3/4	–	–	19008
SA-7NF3/8	3/4	1	3/8	3	–	–	19010
*SA-8	7/8	1	1/4	2-3/4	10303	10300	–
*SA-9	1	1	1/4	2-3/4	10353	10350	–

*3/8 shanks optional

Ordering Information

For more information and / or to place an order, please contact ATA Customer Service at:

US Offices: +1 330-928-7744 or by email sales@atataools.com

UK Offices: +44 (0) 1530 261 145 or by email sales@atagarryson.com

International Offices: +353 (0) 49 432 6178 or by email sales@atagroup.ie

Website: www.atagroup.co

sgspro

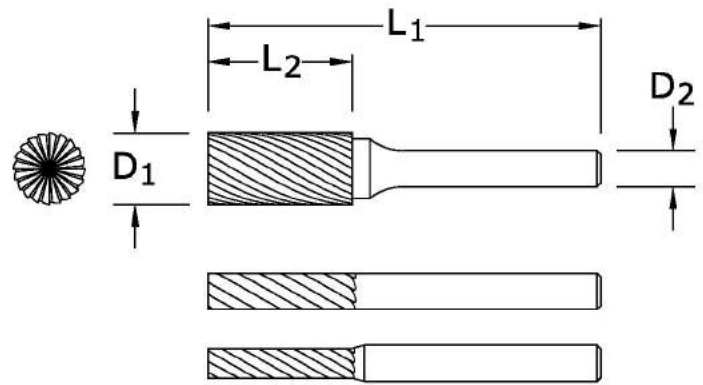

Universal SB - Cylinder Shape

Tool No.	Cutting Diameter D1	Length of Cut L2	Shank Diameter D2	Overall Length L1	Double Cut 6 EDP No.	Single Cut 3 EDP No.	Nonferrous Cut 1 EDP No.
SB-41	1/16	1/4	1/8	1-1/2	11453	11450	–
SB-41L2	1/16	1/4	1/8	2	17253	17250	–
SB-41L3	1/16	1/4	1/8	3	17278	17275	–
SB-42	3/32	7/16	1/8	1-1/2	11478	11475	–
SB-42L2	3/32	7/16	1/8	2	17303	17300	–
SB-42L3	3/32	7/16	1/8	3	17328	17325	–
SB-ECO	1/8	–	1/8	3	–	11525	–
SB-11	1/8	1/2	1/4	2-1/4	11253	11250	–
SB-12	1/8	5/8	1/4	2-3/8	11278	11275	–
SB-43	1/8	9/16	1/8	1-1/2	11503	11500	–
SB-43L2	1/8	9/16	1/8	2	17353	17350	–
SB-43L3	1/8	9/16	1/8	3	17378	17375	–
SB-13	5/32	5/8	1/4	2	11303	11300	–
SB-14	3/16	5/8	1/4	2	10328	10825	–
SB-51	1/4	3/16	1/8	1-3/4	11550	11553	–
SB-1	1/4	5/8	1/4	2	10853	10850	–
SB-1L	1/4	1	1/4	2	10878	10875	–
SB-1NF	1/4	3/4	1/4	2	–	–	19012



Recommended Air Tools

FEATURES
From finishing to stock removal

TOOL
Die Grinders & Pencil Grinders



Wear Eye Protection!



Wear Hearing Protection!



Observe the recommended rotational speed, especially when using burs with long shanks!



Wear Protective Gloves



SB-D/C

SB-S/C

SB-N/F

Universal SB - Cylinder Shape

Tool No.	Cutting Diameter D1	Length of Cut L2	Shank Diameter D2	Overall Length L1	Double Cut 6 EDP No.	Single Cut 3 EDP No.	Nonferrous Cut 1 EDP No.
SB-2	5/16	3/4	1/4	2-1/2	10903	10900	–
SB-3	3/8	3/4	1/4	2-1/2	10928	10925	–
SB-3L	3/8	1	1/4	2-3/4	10953	10950	–
SB-3NF	3/8	3/4	1/4	2-1/2	–	–	19014
SB-3X	3/8	1-1/2	1/4	3-1/4	10978	10975	–
SB-4	7/16	1	1/4	2-3/4	11003	11000	–
SB-5	1/2	1	1/4	2-3/4	11028	11025	–
SB-5NF	1/2	1	1/4	2-3/4	–	–	19016
*SB-6	5/8	1	1/4	2-3/4	11053	11050	–
*SB-6NF	5/8	1	1/4	2-3/4	–	–	19018
*SB-15	3/4	1/2	1/4	2-1/4	11353	11350	–
*SB-16	3/4	3/4	1/4	2-1/2	11403	11400	–
*SB-7	3/4	1	1/4	2-3/4	11103	11100	–
SB-7NF	3/4	1	1/4	2-3/4	–	–	19020
SB-7NF3/8	3/4	1	3/8	3	–	–	19022
*SB-8	7/8	1	1/4	2-3/4	11153	11150	–
*SB-9	1	1	1/4	2-3/4	11203	11200	–

*3/8 shanks optional

Ordering Information

For more information and / or to place an order, please contact ATA Customer Service at:

US Offices: +1 330-928-7744 or by email sales@atatools.com

UK Offices: +44 (0) 1530 261 145 or by email sales@atagarryson.com

International Offices: +353 (0) 49 432 6178 or by email sales@atagroup.ie

Website: www.atagroup.co

sgspro

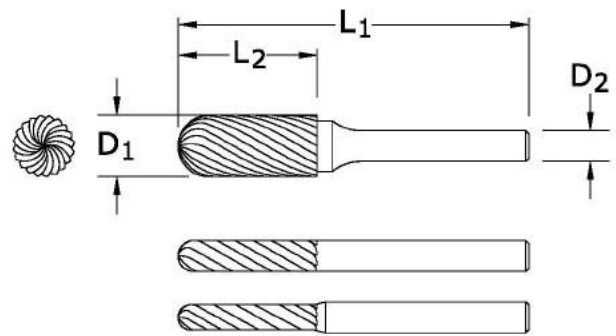

Universal SC - Cylinder Shape

Tool No.	Cutting Diameter D1	Length of Cut L2	Shank Diameter D2	Overall Length L1	Double Cut 6 EDP No.	Single Cut 3 EDP No.	Nonferrous Cut 1 EDP
SC-61	3/32	3/8	3/32	1-1/4	12378	12375	-
SC-41	3/32	7/16	1/8	1-1/2	12253	12250	-
SC-11	1/8	1/2	1/4	2-1/4	12053	12050	-
SC-42	1/8	9/16	1/8	1-1/2	12278	12275	-
SC-42L2	1/8	9/16	1/8	2	17453	17450	-
SC-42L3	1/8	9/16	1/8	3	17478	17475	-
SC-12	1/8	5/8	1/4	2-3/8	12078	12075	-
SC-52	5/32	1/2	1/8	1-1/2	12328	12325	-
SC-13	5/32	5/8	1/4	2	12103	12100	-
SC-81	3/16	1/2	3/16	2	12403	12400	-
SC-53	3/16	1/2	1/8	1-1/2	12353	12350	-
SC-14	3/16	5/8	1/4	2	12128	12125	-
SC-51	1/4	1/2	1/8	2	12303	12300	-
SC-1	1/4	5/8	1/4	2	11703	11700	-
SC-1L	1/4	1	1/4	2	11728	11725	-
SC-1L6	1/4	5/8	1/4	6-1/2	16328	16325	-
SC-1NF	1/4	3/4	1/4	2	-	-	19024
SC-2	5/16	3/4	1/4	2-1/2	11753	11750	-



Recommended Air Tools

FEATURES
From finishing to stock removal

TOOL
Die Grinders & Pencil Grinders



Wear Eye Protection!



Wear Hearing Protection!



Observe the recommended rotational speed, especially when using burs with long shanks!



Wear Protective Gloves



Universal SC - Cylinder Shape

Tool No.	Cutting Diameter D1	Length of Cut L2	Shank Diameter D2	Overall Length L1	Double Cut 6 EDP No.	Single Cut 3 EDP No.	Nonferrous Cut 1 EDP
SC-3	3/8	3/4	1/4	2-1/2	11778	11775	-
SC-3L	3/8	1	1/4	2-3/4	11803	11800	-
SC-3L6	3/8	3/4	1/4	6-3/4	16353	16350	-
SC-3NF	3/8	3/4	1/4	2-1/2	-	-	19026
SC-3X	3/8	1-1/2	1/4	3-1/4	11828	11825	-
SC-4	7/16	1	1/4	2-3/4	11853	11850	-
SC-5	1/2	1	1/4	2-3/4	11878	11875	-
SC-5L6	1/2	1	1/4	7	16378	16375	-
SC-5NF	1/2	1	1/4	2-3/4	-	-	19028
*SC-6	5/8	1	1/4	2-3/4	11903	11900	-
*SC-6NF	5/8	1	1/4	2-3/4	-	-	19030
*SC-15	3/4	1/2	1/4	2-1/4	12153	12150	-
*SC-16	3/4	3/4	1/4	2-1/2	12203	12200	-
*SC-7	3/4	1	1/4	2-3/4	11953	11950	-
SC-7NF	3/4	1	1/4	2-3/4	-	-	19032
SC-7NF3/8	3/4	1	3/8	3	-	-	19034
*SC-9	1	1	1/4	2-3/4	12003	12000	-

*3/8 shanks optional

Ordering Information

For more information and / or to place an order, please contact ATA Customer Service at:

US Offices: +1 330-928-7744 or by email sales@atataools.com

UK Offices: +44 (0) 1530 261 145 or by email sales@atagarryson.com

International Offices: +353 (0) 49 432 6178 or by email sales@atagroup.ie

Website: www.atagroup.co

sgspro

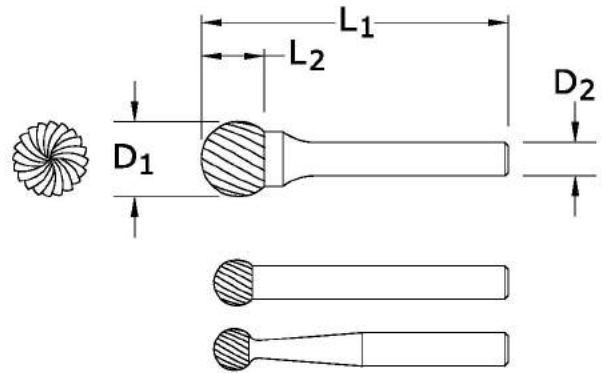

Universal SD - Ball Shape

Tool No.	Cutting Diameter D1	Length of Cut L2	Shank Diameter D2	Overall Length L1	Double Cut 6 EDP No.	Single Cut 3 EDP No.	Nonferrous Cut 1 EDP No.
SD-41	3/32	3/32	1/8	1-1/2	12778	12775	-
SD-61	3/32	3/32	3/32	1-1/4	12878	12875	-
SD-11	1/8	3/32	1/4	2	12728	12725	-
SD-42	1/8	1/8	1/8	1-1/2	12803	12800	-
SD-42L2	1/8	1/8	1/8	2	17553	17550	-
SD-42L3	1/8	1/8	1/8	3	17578	17575	-
SD-52	5/32	5/32	1/8	1-1/2	12840	12837	-
SD-14	3/16	1/8	1/4	2	12753	12750	-
SD-81	3/16	5/32	3/16	2	12903	12900	-
SD-53	3/16	5/32	1/8	1-1/2	12853	12850	-
SD-1	1/4	7/32	1/4	2	12453	12450	-
SD-1L6	1/4	7/32	1/4	6-3/16	16403	16400	-
SD-1NF	1/4	7/32	1/4	2	-	-	19036
SD-51	1/4	7/32	1/8	1-3/4	12828	12825	-



Recommended Air Tools

FEATURES
From finishing to stock removal

TOOL
Die Grinders & Pencil Grinders



Wear Eye Protection!



Wear Hearing Protection!



Observe the recommended rotational speed, especially when using burs with long shanks!



Wear Protective Gloves

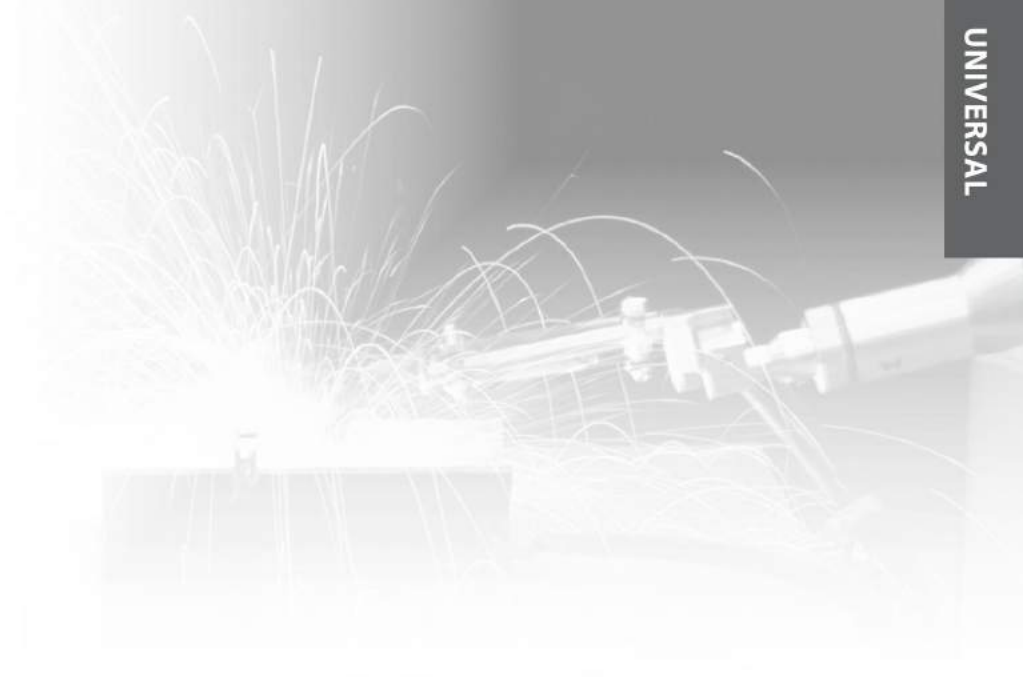

Universal SD - Ball Shape

Tool No.	Cutting Diameter D1	Length of Cut L2	Shank Diameter D2	Overall Length L1	Double Cut 6 EDP No.	Single Cut 3 EDP No.	Nonferrous Cut 1 EDP No.
SD-2	5/16	1/4	1/4	2	12478	12475	-
SD-3	3/8	5/16	1/4	2-1/16	12503	12500	-
SD-3L6	3/8	5/16	1/4	6-5/16	16428	16425	-
SD-3NF	3/8	5/16	1/4	2-1/16	-	-	19038
SD-4	7/16	3/8	1/4	2-1/8	12528	12525	-
SD-5	1/2	7/16	1/4	2-1/8	12553	12550	-
SD-5L6	1/2	7/16	1/4	6-7/16	16453	16450	-
SD-5NF	1/2	7/16	1/4	2-1/8	-	-	19040
*SD-6	5/8	9/16	1/4	2-1/4	12578	12575	-
*SD-6NF	5/8	9/16	1/4	2-1/4	-	-	19042
*SD-7	3/4	11/16	1/4	2-1/2	12628	12625	-
SD-7NF	3/4	11/16	1/4	2-1/2	-	-	19044
SD-7NF3/8	3/4	11/16	3/8	2-11/16	-	-	19046
*SD-9	1	15/16	1/4	2-7/8	12678	12675	-

*3/8 shanks optional

Ordering Information

For more information and / or to place an order, please contact ATA Customer Service at:

US Offices: +1 330-928-7744 or by email sales@atatools.com

UK Offices: +44 (0) 1530 261 145 or by email sales@atagarryson.com

International Offices: +353 (0) 49 432 6178 or by email sales@atagroup.ie

Website: www.atagroup.co

sgspro

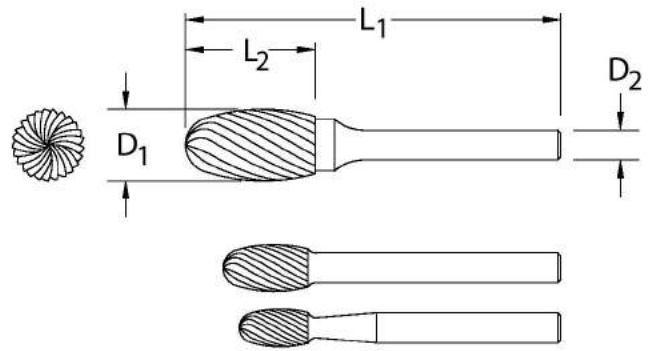

Universal SE - Oval Shape

Tool No.	Cutting Diameter D1	Length of Cut L2	Shank Diameter D2	Overall Length L1	Double Cut 6 EDP No.	Single Cut 3 EDP No.	Nonferrous Cut 1 EDP No.
SE-61	3/32	1/8	3/32	1-1/4	13228	13225	-
SE-41	1/8	7/32	1/8	1-1/2	13153	13150	-
SE-41L2	1/8	7/32	1/8	2	17603	17600	-
SE-41L3	1/8	7/32	1/8	3	17628	17625	-
SE-81	3/16	9/32	3/16	2	13253	13250	-
SE-53	3/16	9/32	1/8	1-1/2	13203	13200	-
SE-11	3/16	5/16	1/4	2	13128	13125	-
SE-1	1/4	3/8	1/4	2	12953	12950	-
SE-1L6	1/4	3/8	1/4	6-3/8	16478	16475	-
SE-51	1/4	3/8	1/8	1-7/8	13178	13175	-
SE-3	3/8	5/8	1/4	2-3/8	12978	12975	-
SE-3L6	3/8	5/8	1/4	6-5/8	16503	16500	-
SE-3NF	3/8	5/8	1/4	2-3/8	-	-	19048
SE-5	1/2	7/8	1/4	2-5/8	13003	13000	-
SE-5L6	1/2	7/8	1/4	6-7/8	16528	16525	-
SE-5NF	1/2	7/8	1/4	2-5/8	-	-	19050
*SE-6	5/8	1	1/4	2-3/4	13028	13025	-
*SE-6NF	5/8	1	1/4	2-3/4	-	-	19052
*SE-7	3/4	1	1/4	2-3/4	13078	13075	-
SE-7NF	3/4	1	1/4	2-3/4	-	-	19054
SE-7NF3/8	3/4	1	3/8	2-3/4	-	-	19056
*SE-7MNF	19.0	25.0	6.0	69.0	-	-	29054
SE-7MNF	19.0	25.0	8.0	69.0	-	-	29056

*3/8 shanks optional



Recommended Air Tools

FEATURES
From finishing to stock removal

TOOL
Die Grinders & Pencil Grinders



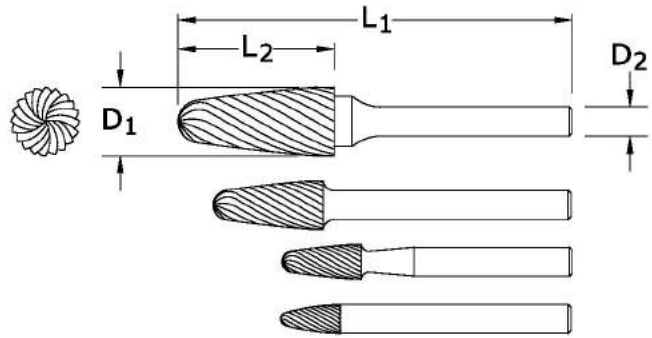

Universal SF - Tree Shape

Tool No.	Cutting Diameter D1	Length of Cut L2	Shank Diameter D2	Overall Length L1	Double Cut 6 EDP No.	Single Cut 3 EDP No.	Nonferrous Cut 1 EDP
SF-61	3/32	1/4	3/32	1-1/4	13778	13775	-
SF-41	1/8	1/4	1/8	1-1/2	13678	13675	-
SF-11	1/8	1/2	1/4	2-1/4	13503	13500	-
SF-42	1/8	1/2	1/8	1-1/2	13703	13700	-
SF-42L2	1/8	1/2	1/8	2	17653	17650	-
SF-42L3	1/8	1/2	1/8	3	17678	17675	-
SF-81	3/16	1/2	3/16	2	13803	13800	-
SF-53	3/16	1/2	1/8	1-1/2	13753	13750	-
SF-51	1/4	1/2	1/8	2	13728	13725	-
SF-1	1/4	5/8	1/4	2	13303	13300	-
SF-1L6	1/4	5/8	1/4	6-1/2	16553	16550	-
SF-1NF	1/4	3/4	1/4	2	-	-	19058
SF-3	3/8	3/4	1/4	2-1/2	13328	13325	-
SF-3L6	3/8	3/4	1/4	6-3/4	16578	16575	-
SF-3NF	3/8	3/4	1/4	2-1/2	-	-	19060
SF-4	7/16	1	1/4	2-3/4	13353	13350	-
SF-13	1/2	3/4	1/4	2-1/2	13528	13525	-
SF-5	1/2	1	1/4	2-3/4	13378	13375	-
SF-5L6	1/2	1	1/4	7	16603	16600	-
SF-5NF	1/2	1	1/4	2-3/4	-	-	19062
*SF-6	5/8	1	1/4	2-3/4	13403	13400	-
*SF-6NF	5/8	1	1/4	2-3/4	-	-	19064
*SF-7	3/4	1	1/4	2-3/4	13453	13450	-
*SF-14	3/4	1-1/4	1/4	3	13578	13575	-
SF-14NF	3/4	1-1/4	1/4	3	-	-	19066
SF-14NF3/8	3/4	1-1/4	3/8	3-1/4	-	-	19068
*SF-15	3/4	1-1/4	1/4	3-1/4	13628	13625	-

*3/8 shanks optional



Ordering Information

For more information and / or to place an order, please contact ATA Customer Service at:

US Offices: +1 330-928-7744 or by email sales@atapro.com

UK Offices: +44 (0) 1530 261 145 or by email sales@atagarryson.com

International Offices: +353 (0) 49 432 6178 or by email sales@atagroup.ie

Website: www.atagroup.co

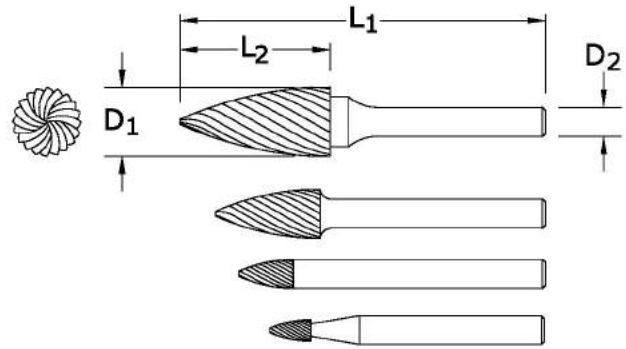

Universal SG - Tree Shape Pointed End

Tool No.	Cutting Diameter D1	Length of Cut L2	Shank Diameter D2	Overall Length L1	Double Cut 6 EDP No.	Single Cut 3 EDP No.	Nonferrous Cut 1 EDP No.
SG-61	3/32	1/4	3/32	1-1/4	14303	14300	-
SG-41	1/8	1/4	1/8	1-1/2	14153	14150	-
SG-42	1/8	5/16	1/8	1-1/2	14178	14175	-
SG-43	1/8	3/8	1/8	1-1/2	14203	14200	-
SG-44	1/8	1/2	1/8	1-1/2	14228	14225	-
SG-44L2	1/8	1/2	1/8	2	17853	17850	-
SG-44L3	1/8	1/2	1/8	3	17878	17875	-
SG-81	3/16	1/2	3/16	2	14328	14325	-
SG-53	3/16	1/2	1/8	1-1/2	14278	14275	-
SG-1	1/4	5/8	1/4	2	13853	13850	-
SG-1L6	1/4	1/2	1/4	6-1/2	16628	16625	-
SG-51	1/4	1/2	1/8	2	14253	14250	-
SG-2	5/16	3/4	1/4	2-1/2	13878	13875	-
SG-3	3/8	3/4	1/4	2-1/2	13903	13900	-
SG-3L6	3/8	3/4	1/4	6-3/4	16653	16650	-
SG-13	1/2	3/4	1/4	2-1/2	14053	14050	-
SG-5	1/2	1	1/4	2-3/4	13928	13925	-
SG-5L6	1/2	1	1/4	7	16678	16675	-
*SG-6	5/8	1	1/4	2-3/4	13953	13950	-
*SG-7	3/4	1	1/4	2-3/4	14003	14000	-
*SG-15	3/4	1-1/2	1/4	3-1/4	14103	14100	-

*3/8 shanks optional



Recommended Air Tools

FEATURES
From finishing to stock removal

TOOL
Die Grinders & Pencil Grinders



Wear Eye Protection!



Wear Hearing Protection!



Observe the recommended rotational speed, especially when using burs with long shanks!



Wear Protective Gloves

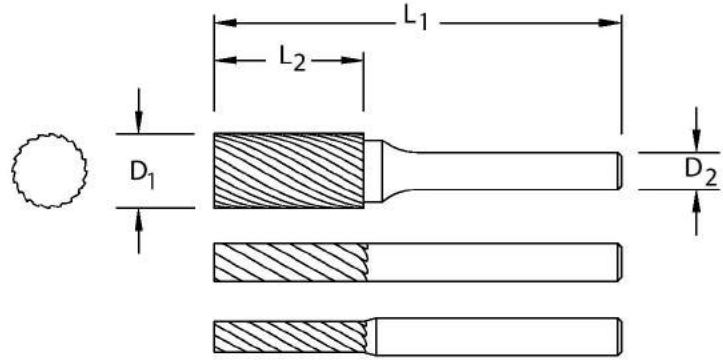

Universal SA - Cylinder Shape

Tool No.	Cutting Diameter D1	Length of Cut L2	Shank Diameter D2	Overall Length L1	Double Cut 6 EDP No.	Single Cut 3 EDP No.	Nonferrous Cut 1 EDP No.
SA-41	1/16	1/4	1/8	1-1/2	10603	10600	-
SA-41L2	1/16	1/4	1/8	2	17103	17100	-
SA-41L3	1/16	1/4	1/8	3	17128	17125	-
SA-61	1/16	1/4	3/32	1-1/4	10753	10750	-
SA-63	3/32	3/8	3/32	1-1/4	10778	10775	-
SA-42	3/32	7/16	1/8	1-1/2	10628	10625	-
SA-42L2	3/32	7/16	1/8	2	17153	17150	-
SA-42L3	3/32	7/16	1/8	3	17178	17175	-
SA-11	1/8	1/2	1/4	2-1/4	10403	10400	-
SA-43	1/8	9/16	1/8	1-1/2	10653	10650	-
SA-43L2	1/8	9/16	1/8	2	17203	17200	-
SA-43L3	1/8	9/16	1/8	3	17228	17225	-
SA-12	1/8	5/8	1/4	2-3/8	10428	10425	-
SA-52	5/32	1/2	1/8	1-1/2	10703	10700	-
SA-13	5/32	5/8	1/4	2	10453	10450	-
SA-81	3/16	1/2	3/16	2	10803	10800	-
SA-53	3/16	1/2	1/8	1-1/2	10728	10725	-
SA-14	3/16	5/8	1/4	2	10478	10475	-
SA-51	1/4	1/2	1/8	2	10678	10675	-
SA-1	1/4	5/8	1/4	2	10003	10000	-
SA-1L	1/4	1	1/4	2	10028	10025	-
SA-1L6	1/4	5/8	1/4	6-1/2	16178	16175	-



Recommended Air Tools

FEATURES
From finishing to stock removal

TOOL
Die Grinders & Pencil Grinders



Wear Eye Protection!



Wear Hearing Protection!



Observe the recommended rotational speed, especially when using burs with long shanks!



Wear Protective Gloves

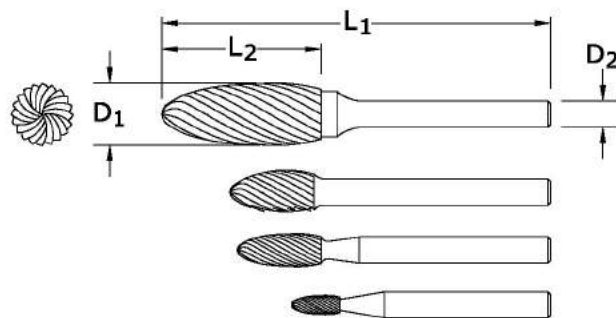

Universal SH - Flame Shape

Tool No.	Cutting Diameter D1	Length of Cut L2	Shank Diameter D2	Overall Length L1	Double Cut 6 EDP No.	Single cut 3 EDP No.
SH-41	1/8	1/4	1/8	1-1/2	14553	14550
SH-41L2	1/8	1/4	1/8	2	17903	17900
SH-41L3	1/8	1/4	1/8	3	17928	17925
SH-53	3/16	3/8	1/8	1-1/2	14603	14600
SH-1	1/4	5/8	1/4	2	14378	14375
SH-2	5/16	3/4	1/4	2-1/2	14403	14400
SH-2L6	5/16	3/4	1/4	6-3/4	16703	16700
SH-5	1/2	1-1/4	1/4	3	14428	14425
SH-5L6	1/2	1-1/4	1/4	7-1/4	16728	16725
*SH-6	5/8	1-7/16	1/4	3-1/8	14453	14450
*SH-7	3/4	1-5/8	1/4	3-3/8	14503	14500

*3/8 shanks optional



Ordering Information

For more information and / or to place an order, please contact ATA Customer Service at:

US Offices: +1 330-928-7744 or by email sales@atatools.com

UK Offices: +44 (0) 1530 261 145 or by email sales@atagarryson.com

International Offices: +353 (0) 49 432 6178 or by email sales@atagroup.ie

Website: www.atagroup.co

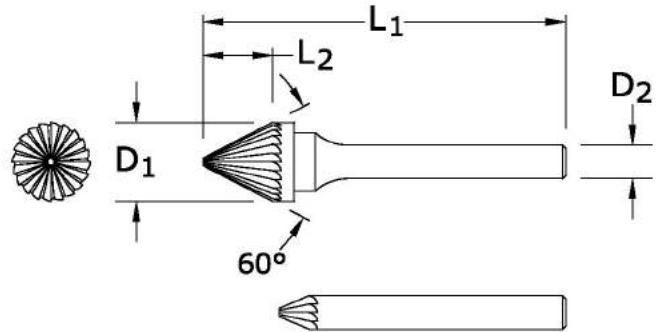

Universal SJ - Cone Shape

Tool No.	Cutting Diameter D1	Length of Cut L2	Shank Diameter D2	Overall Length L1	Double Cut 6 EDP No.	Single Cut 3 EDP No.
SJ-42	1/8	3/32	1/8	1-1/2	14903	14900
SJ-1	1/4	3/16	1/4	2	14678	14675
SJ-3	3/8	5/16	1/4	2-1/8	14703	14700
SJ-5	1/2	7/16	1/4	2-5/16	14728	14725
*SJ-6	5/8	9/16	1/4	2-3/8	14753	14750
*SJ-7	3/4	11/16	1/4	2-9/16	14803	14800
*SJ-9	1	15/16	1/4	2-5/8	14853	14850

*3/8 shanks optional



Recommended Air Tools

FEATURES
From finishing to stock removal

TOOL
Die Grinders & Pencil Grinders



Wear Eye Protection!



Wear Hearing Protection!



Observe the recommended rotational speed, especially when using burs with long shanks!



Wear Protective Gloves

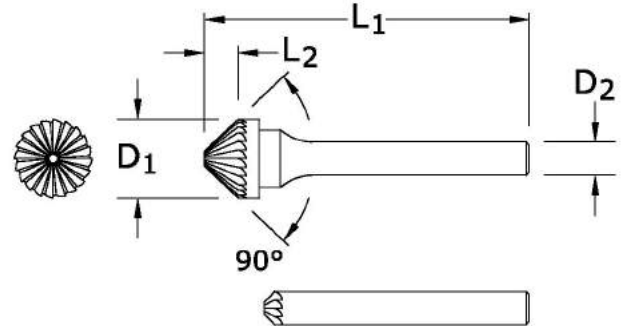

Universal SK - Cone Shape

Tool No.	Cutting Diameter D1	Length of Cut L2	Shank Diameter D2	Overall Length L1	Double Cut 6 EDP No.	Single Cut 3 EDP No.
SK-42	1/8	1/16	1/8	1-1/2	15153	15150
SK-1	1/4	1/8	1/4	2	14928	14925
SK-3	3/8	3/16	1/4	2-1/16	14953	14950
SK-5	1/2	1/4	1/4	2-1/8	14978	14975
*SK-6	5/8	5/16	1/4	2-1/4	15003	15000
*SK-7	3/4	3/8	1/4	2-5/16	15053	15050
*SK-9	1	1/2	1/4	2-3/8	15103	15100

*3/8 shanks optional



Ordering Information

For more information and / or to place an order, please contact ATA Customer Service at:

US Offices: +1 330-928-7744 or by email sales@atataools.com

UK Offices: +44 (0) 1530 261 145 or by email sales@atagarryson.com

International Offices: +353 (0) 49 432 6178 or by email sales@atagroup.ie

Website: www.atagroup.co

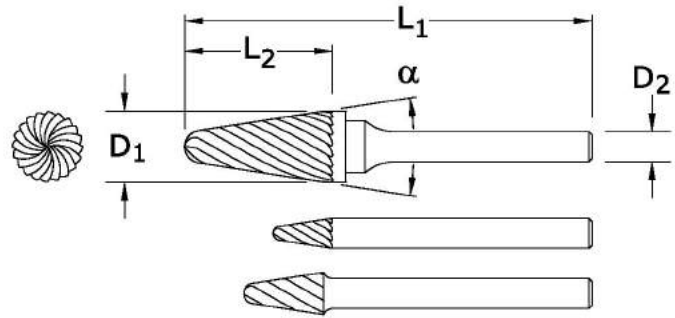

Universal SL - Radius End Taper Shape

Tool No.	Cutting Diameter D1	Length of Cut L2	Shank Diameter D2	Overall Length L1	Included Angle α	Double Cut 6 EDP No.	Single Cut 3 EDP No.	Nonferrous Cut 1 EDP No.
SL-41	1/8	3/8	1/8	1-1/2	8°	15403	15400	-
SL-42	1/8	1/2	1/8	1-1/2	8°	15428	15425	-
SL-42L2	1/8	1/2	1/8	2	8°	17953	17950	-
SL-42L3	1/8	1/2	1/8	3	8°	17978	17975	-
SL-81	3/16	7/16	3/16	2	14°	15478	15475	-
SL-53	3/16	1/2	1/8	1-1/2	14°	15453	15450	-
SL-1	1/4	5/8	1/4	2	14°	15178	15175	-
SL-1L6	1/4	5/8	1/4	6-3/4	14°	16753	16750	-
SL-2	5/16	7/8	1/4	2-3/4	14°	15203	15200	-
SL-3	3/8	1-1/16	1/4	3	14°	15228	15225	-
SL-3L6	3/8	1-1/16	1/4	7-1/16	14°	16778	16775	-
SL-3NF	3/8	1-1/16	1/4	3	14°	-	-	19070
SL-4	1/2	1-1/8	1/4	3	14°	15253	15250	-
SL-4L6	1/2	1-1/8	1/4	7-1/16	14°	16803	16800	-
SL-4NF	1/2	1-1/8	1/4	7-1/16	14°	-	-	19072
SL-5	5/8	1-3/16	1/4	3-1/16	14°	15278	15275	-

*3/8 shanks optional



Recommended Air Tools

FEATURES
From finishing to stock removal

TOOL
Die Grinders & Pencil Grinders



SL-D/C

SL-S/C

SL-NF

Universal SL - Taper Shape

Tool No.	Cutting Diameter D1	Length of Cut L2	Shank Diameter D2	Overall Length L1	Included Angle α	Double Cut 6 EDP No.	Single Cut 3 EDP No.	Nonferrous Cut 1 EDP No.
*SL-5NF	5/8	1-3/16	1/4	3	14°	–	–	19074
*SL-6	5/8	1-5/16	1/4	3-3/16	14°	15303	15300	–
*SL-6NF	5/8	1-5/16	1/4	3-3/16	14°	–	–	19076
*SL-7	3/4	1-1/2	1/4	3-3/8	14°	15353	15350	–
SL-7NF	3/4	1-1/2	1/4	3-3/8	14°	–	–	19078
SL-7NF3/8	3/4	1-1/2	3/8	3-5/8	14°	–	–	19080

*3/8 shanks optional

Ordering Information

For more information and / or to place an order, please contact ATA Customer Service at:

US Offices: +1 330-928-7744 or by email sales@atatools.com

UK Offices: +44 (0) 1530 261 145 or by email sales@atagarryson.com

International Offices: +353 (0) 49 432 6178 or by email sales@atagroup.ie

Website: www.atagroup.co

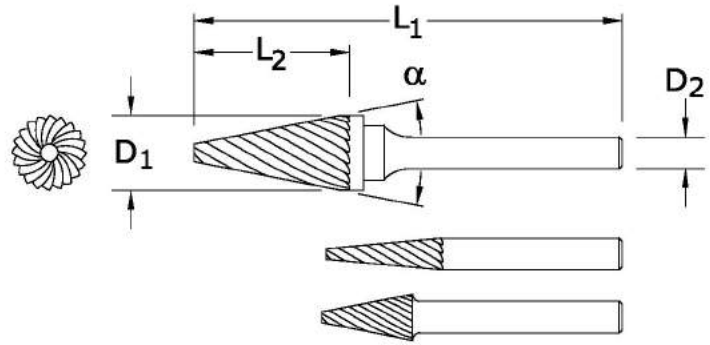

Universal SM - Cone Shape

Tool No.	Cutting Diameter D1	Length of Cut L2	Shank Diameter D2	Overall Length L1	Included Angle α	Double Cut 6 EDP No.	Single Cut 3 EDP No.
SM-61	3/32	1/4	3/32	1-1/4	10°	15803	15800
SM-41	1/8	11/32	1/8	1-1/2	12°	15678	15675
SM-42	1/8	7/16	1/8	1-1/2	14°	15703	15700
SM-42L2	1/8	7/16	1/8	2	14°	18053	18050
SM-42L3	1/8	7/16	1/8	3	14°	18078	18075
SM-43	1/8	5/8	1/8	1-1/2	7°	15728	15725
SM-53	3/16	1/2	1/8	1-1/2	16°	15778	15775
SM-1	1/4	1/2	1/4	2	22°	15503	15500
SM-51	1/4	1/2	1/8	2-3/32	22°	15753	15750
SM-2	1/4	3/4	1/4	2	14°	15528	15525
SM-3	1/4	1	1/4	2	10°	15553	15550
SM-4	3/8	5/8	1/4	2-1/2	28°	15578	15575
SM-5	1/2	7/8	1/4	2-3/4	28°	15603	15600
*SM-6	5/8	1	1/4	2-7/8	31°	15628	15625

*3/8 shanks optional



Recommended Air Tools

FEATURES

From finishing to stock removal

TOOL

Die Grinders & Pencil Grinders

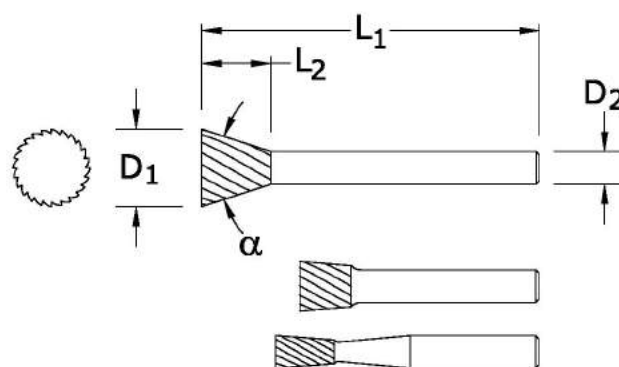

Universal SN - Cone Shape Inverted

Tool No.	Cutting Diameter D1	Length of Cut L2	Shank Diameter D2	Overall Length L1	Included Angle α	Double Cut 6 EDP No.	Single Cut 3 EDP No.
SN-41	3/32	1/8	1/8	1-1/2	10°	16028	16025
SN-61	3/32	1/8	3/32	1-1/4	10°	16128	16125
SN-42	1/8	3/16	1/8	1-1/2	10°	16053	16050
SN-81	3/16	1/4	3/16	2	10°	16153	16150
SN-53	3/16	1/4	1/8	1-1/2	10°	16103	16100
SN-51	1/4	1/4	1/8	1-3/4	10°	16078	16075
SN-1	1/4	5/16	1/4	2	10°	15853	15850
SN-2	3/8	3/8	1/4	2-3/32	13°	15878	15875
SN-4	1/2	1/2	1/4	2-1/4	28°	15903	15900
*SN-6	5/8	3/4	1/4	2-1/2	18°	15928	15925
*SN-7	3/4	5/8	1/4	2-3/8	30°	15978	15975

*3/8 shanks optional



Ordering Information

For more information and / or to place an order, please contact ATA Customer Service at:

US Offices: +1 330-928-7744 or by email sales@atatools.com

UK Offices: +44 (0) 1530 261 145 or by email sales@atagarryson.com

International Offices: +353 (0) 49 432 6178 or by email sales@atagroup.ie

Website: www.atagroup.co



Universal Long Shank

Tool No.	Cutting Diameter	Length of Cut	Shank Diameter	Overall Length	Double Cut 6 EDP No.	Single Cut 3 EDP No.
Cylinder Shape						
SA-1L6	1/4	1/2	1/4	6-1/2	16178	16175
SA-3L6	3/8	3/4	1/4	6-3/4	16203	16200
SA-5L6	1/2	1	1/4	7	16228	16225
Cylinder Shape Radius End						
SC-1L6	1/4	1/2	1/4	6-1/2	16328	16325
SC-3L6	3/8	3/4	1/4	6-3/4	16353	16350
SC-5L6	1/2	1	1/4	7	16378	16375
Ball Shape						
SD-1L6	1/4	7/32	1/4	6-3/16	16403	16400
SD-3L6	3/8	5/16	1/4	6-5/16	16428	16425
SD-5L6	1/2	7/16	1/4	6-7/16	16453	16450
Oval Shape						
SE-1L6	1/4	3/8	1/4	6-3/8	16478	16475
SE-3L6	3/8	5/8	1/4	6-5/8	16503	16500
SE-5L6	1/2	7/8	1/4	6-7/8	16528	16525
Tree Shape Radius End						
SF-1L6	1/4	1/2	1/4	6-1/2	16553	16550
SF-3L6	3/8	3/4	1/4	6-3/4	16578	16575
SF-5L6	1/2	1	1/4	7	16603	16600
Tree Shape Pointed End						
SG-1L6	1/4	1/2	1/4	6-1/2	16628	16625
SG-3L6	3/8	3/4	1/4	6-3/4	16653	16650
SG-5L6	1/2	1	1/4	7	16678	16675
Flame Shape						
SH-2L6	5/16	3/4	1/4	6-3/4	16703	16700
SH-5L6	1/2	1-1/4	1/4	7-1/4	16728	16725
14° Taper Radius End						
SL-1L6	1/4	5/8	1/4	6-5/8	16753	16750
SL-3L6	3/8	1-1/16	1/4	7-1/16	16778	16775
SL-4L6	1/2	1-1/8	1/4	7-1/16	16803	16800

Maximum recommended speeds for extended length shanks is 15,000rpm